

# VPL400-X VERTICAL PLATFORM LIFT



**OWNER'S  
MANUAL**



## **THANK YOU**

From all of us at Harmar, thank you for placing your trust in our products and allowing us to be a part of your journey.

For more than 20 years we have been committed to creating products that help you maintain independence. With a drive to empower people to live as they choose, Harmar Lifts Lives.

Beyond vertical platform lifts, like the one you've purchased, Harmar designs and manufactures Vehicle Lifts, award-winning Stair Lifts, and more.

We strive to be the leading provider of lift assisting technology in your home and on the road.

Visit [harmar.com](http://harmar.com) or speak to your dealer about the other solutions available from Harmar.

**TABLE OF CONTENTS**

**SAFETY** ..... 4  
Safety Definitions..... 4  
Special Cautions..... 4

**INTRODUCTION** ..... 5  
Device Name: Harmar Highlander 400-X VPL..... 5  
Read and Understand..... 5  
Purchasing Information ..... 5  
Technical Specifications ..... 5  
Code Statement ..... 5  
Key Vertical Platform Lift Elements..... 6  
Key Internal Vertical Platform Lift Elements..... 7

**OPERATION** ..... 8  
How the Harmar Highlander 400-X Works..... 8  
Lift Operation ..... 8  
Call/Send ..... 8  
Entering the Platform with Platform Gate ..... 8  
Entering the Platform with Auto-Fold Ramp ..... 9  
Operating the Platform Controls ..... 9  
Exiting the Platform ..... 9  
Recommendations ..... 10  
Emergency Lowering Procedure ..... 10

**CARE**..... 12

**MAINTENANCE & INSPECTION**..... 13  
Residential Applications ..... 13  
Maintenance Schedule ..... 13  
Maintenance/Service Record ..... 14

**WARRANTY** ..... 16



SECTION 1

**SAFETY**

**SAFETY DEFINITIONS**



This safety alert symbol appears with safety statements. It means attention, become alert, your safety and the safety of others are involved! Please read and abide by the message that follows the safety alert symbol.

 **WARNING**

Indicates a hazardous situation that, if not avoided, could result in death or serious injury.

 **CAUTION**

Indicates a hazardous situation that, if not avoided, could result in minor or moderate injury.

**NOTICE**

*Indicates a situation which can cause damage to the lift and/or the environment, or cause the lift to operate improperly.*

*NOTE: Indicates a condition that should be followed in order for the lift to function in the manner intended.*

**SPECIAL CAUTIONS**



Pay attention to the following Special Cautions while operating your vertical platform lift.

- Do not exceed the maximum payload capacity of 750 lb.
- Do not ride on a lift that is not anchored in place.
- Make sure any obstructions are cleared from underneath the platform area before use.
- Make sure both the passenger and wheelchair are completely on the platform before using.
- Do not disable any safety equipment or switches supplied with this lift.
- Do not attempt to service the lift yourself. Contact your Harmar dealer for assistance.
- Do not allow children to operate or play around the lift.
- Do not enter or exit a platform by climbing over a gate or side panel.
- Keep feet, hands, arms, legs and body well within the confines of the platform during transport.
- Do not hold onto the top of the side panel or gate during transport as this creates a potential pinch hazard.
- This product is designed only for lifting people and wheelchairs within the specified load capacity. Do not use it for freight or any other purpose.
- Read all instructions in this manual before installing or operating the lift.

## SECTION 2 **INTRODUCTION**

### **DEVICE NAME: HIGHLANDER 400-X VERTICAL PLATFORM LIFT**

Indications of Use:  
The Harmar Highlander 400-X Vertical Platform Lift is to aid in the safe and efficient transfer of individuals with limited mobility or disabilities, along with their mobility devices, between different levels of a residential building.

### **READ AND UNDERSTAND**

This manual provides instructions for proper use and maintenance of your Vertical Platform Lift. Please refer to this Owner's Manual for operating instructions. Any alterations to the equipment without written authorization by the manufacturer is prohibited and will void the warranty.

### **PURCHASING INFORMATION**

If you have questions concerning the operation and maintenance of your Vertical Platform, please contact your dealer.

Please ensure that you fill out the separate warranty form and return it within ten (10) days of purchase to register your lift.

### **TECHNICAL SPECIFICATIONS**

Visit [harmar.com](http://harmar.com) for specifications on your lift model.

### **CODE STATEMENT**

Your lift has been designed to meet Safety standard ASME A18.1-2020 for Platform Lifts and Stairway Chairlifts" under section 5 and has been certified to CSA B44.1/ASME A17.1-2019 "Elevator and Escalator Electrical Equipment".

Code requirements for Vertical Platform lifts may vary depending on location. It is the installer's responsibility to contact their state, city or local code enforcement office and determine all the regulations the lift and installation are subject to. This must be done before installing the Vertical Platform Lift.

Harmar Vertical Platform Lifts are to be installed in accordance with all applicable codes and in accordance with Safety standard ASME A18.1-2020/CSA B44.1/ASME A17.1-2019.

The VPL400-X Vertical Platform Lift is intended for maximum operation of 6 cycles per hour.

# INTRODUCTION

## KEY VERTICAL PLATFORM LIFT ELEMENTS

1. Top Cap
2. Decal
3. Data Serial Tag
4. Platform
5. Platform Guard Panel
6. Grab Rail (if supplied)
7. Platform Controls
8. Platform Safety Pan
9. Platform Folding Ramp/  
Platform Fixed Ramp
10. Tower
11. Folding Ramp Actuator Tube

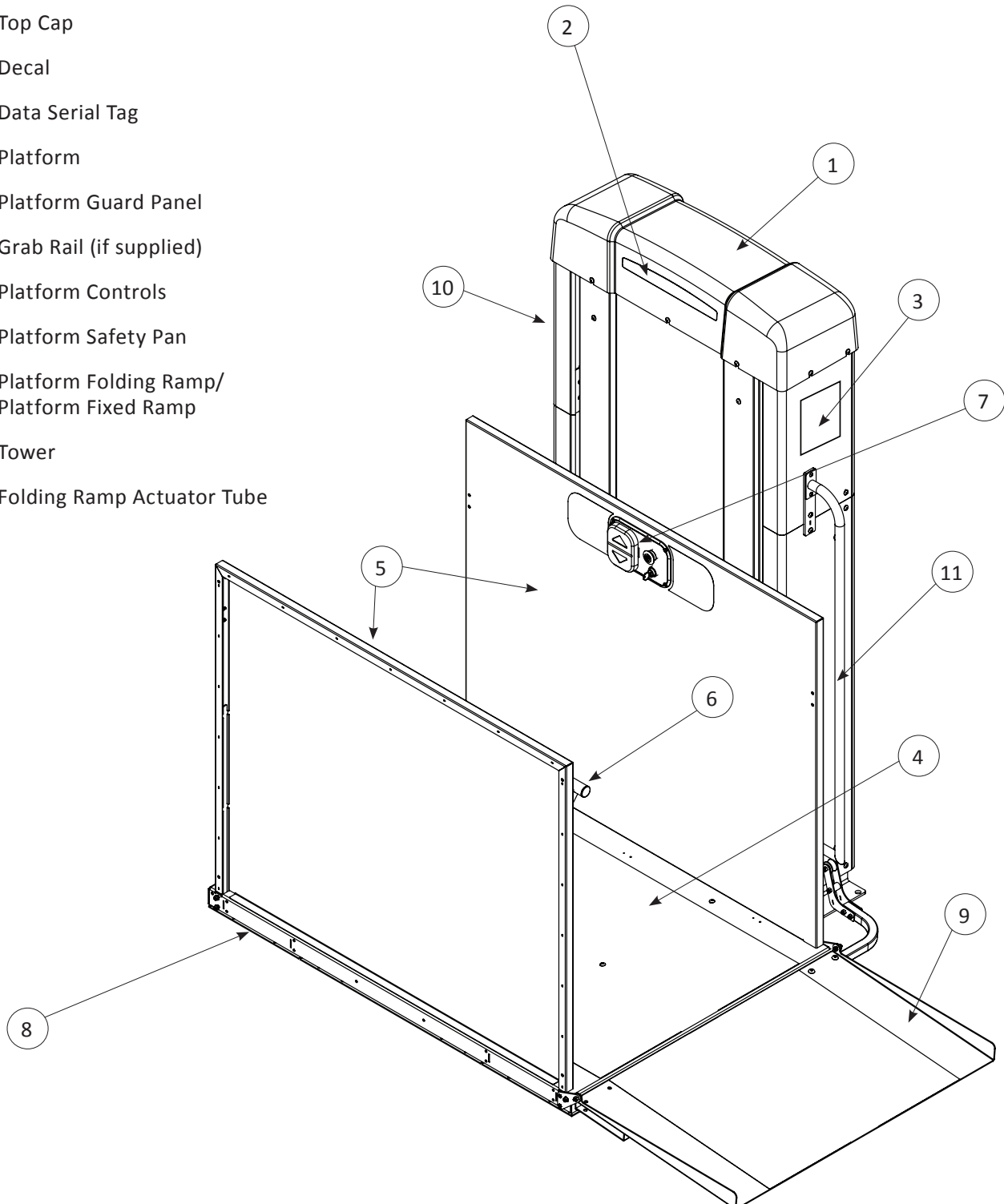

## KEY INTERNAL VERTICAL PLATFORM LIFT ELEMENTS

1. Manual Lowering Tool
2. Motor / Gearbox
3. ACME Screw with Drive and Safety nuts
4. Control Electronics Assembly
5. Tower Frame
6. Tower Legs
7. Wire Channel
8. Over-Speed Safety Assembly
9. Motor Contactors
10. Carriage
11. Trailing Cable
12. Cable Tensioning Pulley
13. Junction Box (Main Power Supply Hookup)

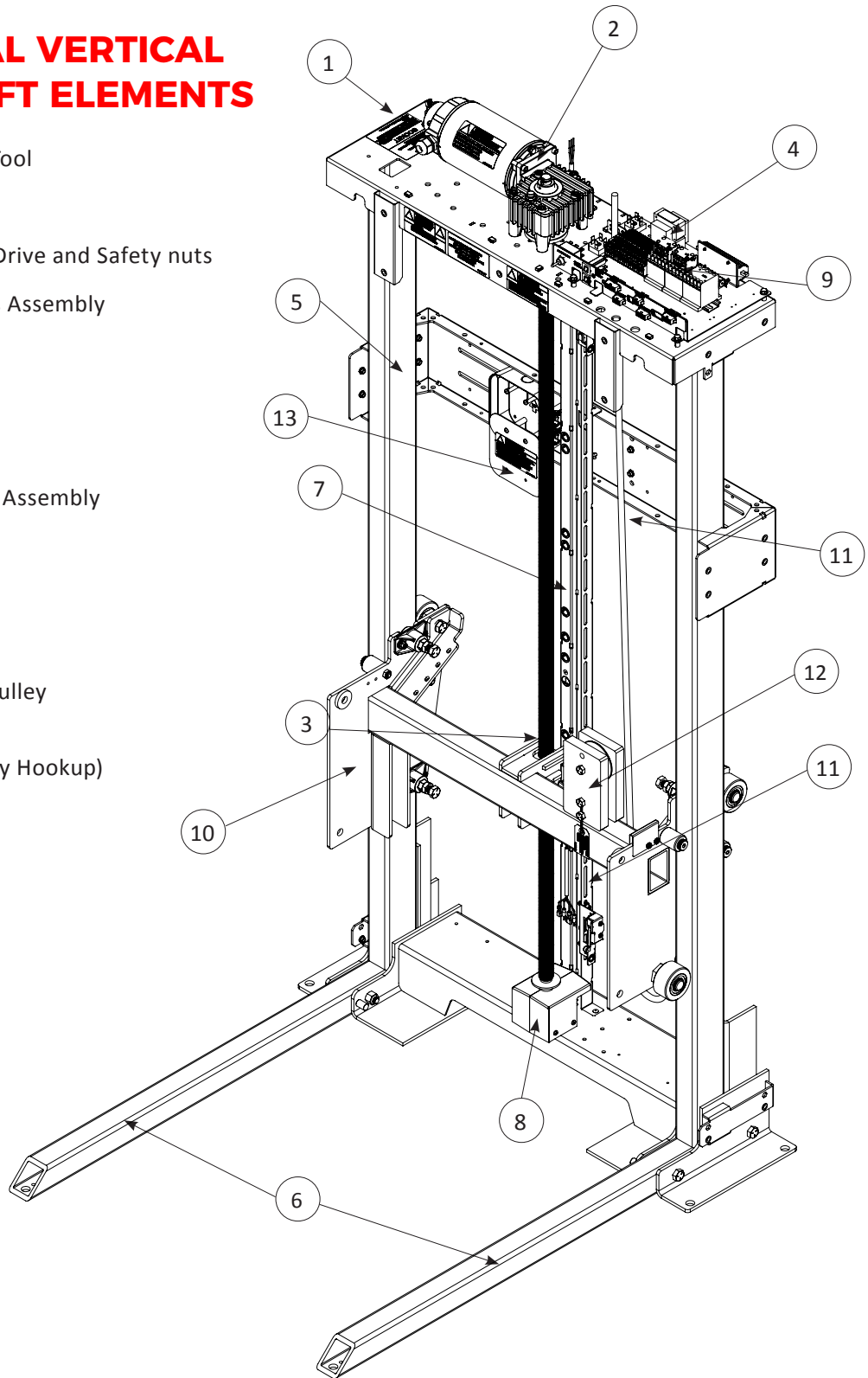

SECTION 3

**OPERATION**

**HOW THE HARMAR HIGHLANDER 400-X WORKS**

The Harmar Highlander 400-X Vertical Platform Lift is AC powered via 115V AC, 15A, single phase, 60Hz.

The lift is interlocked and will not operate unless all auxiliary gates and appropriate safeties are engaged. The lift will raise or lower once a control input is activated - whether from a call station or from the platform. A control switch must be continually pressed for the platform to move.

The lifting/lowering of the platform is achieved with a ¾ hp electric motor and gear box driving an ACME screw. That screw system connects to the platform carriage which in turn supports the platform. The platform automatically stops at the desired landing.

The lift has several advanced safety systems based on the status of various sensors and switches located in the tower and at landings. Once a lift is at a landing, the gates/doors will be unlocked and are able to be opened.

**LIFT OPERATION**

**CAUTION**

Prior to every use, please be sure to look around the lift for any signs of damage. Visually inspect anchoring bolts and tower braces and make sure that they are securely in place. Do not use lift if there are any missing or damaged fasteners or other components, they need to be replaced by a qualified technician to ensure continued safe operation.

**CALL/SEND**

If the platform is not at your desired landing, you will need to “call” or “send” for it. A Call/Send Control is located at the landing or in the gate frame. The Call/Send Control may have a keylock. Please ensure the key is rotated to the “On” position. Then, to call or send the platform, simply press the Up or Down button, continuously, until the platform comes to a full stop at the desired landing.

*NOTE: If there is a platform gate or landing gate, it will not open unless the platform is aligned with the interlock.*

**ENTERING THE PLATFORM WITH PLATFORM GATE**

Enter the platform either by opening the gate/door towards you or moving through the opening. Move to the center of the platform while closing the gate/door behind you. If your mobility device has a brake, make sure to engage it. *See Figure 3-1.*

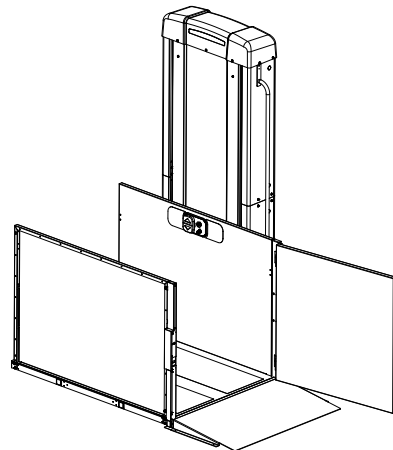

Figure 3-1



## ENTERING THE PLATFORM WITH AUTO-FOLD RAMP

Enter platform through opening. Be sure all body parts and wheelchair parts are completely inside the platform. When you control the lift to go up, the auto ramp will gradually close and be complete after 13" of vertical travel. *See Figure 3-2.*

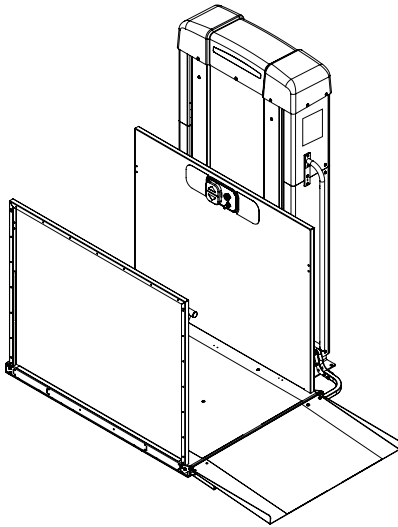

Figure 3-2

## OPERATING THE PLATFORM CONTROLS

Once you are on the platform, locate the Platform Controls on the side panel. If the unit has a key switch, insert the key and turn the key to the "On" position. *See Figure 3-3.*

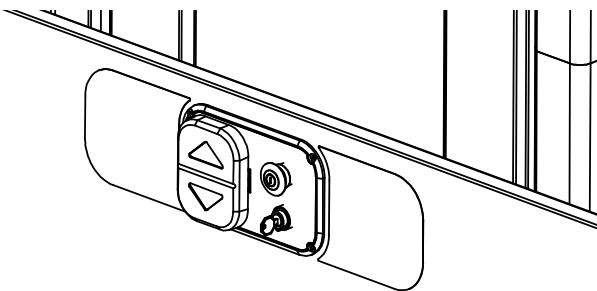

Figure 3-3

Once you have confirmed that your unit is on, simply press the desired (up or down) arrow on the blue paddle. The lift will move as long as the paddle control is pressed until you come to a full stop at the desired landing.

### CAUTION

If you release the blue paddle switch and the unit continues to move, press the Red Emergency Stop Button on the control panel to stop immediately.

### WARNING

Do not hold onto the top of the side panel or gate during transport. Keep feet, hands, arms, legs and body well within the confines of the platform during transport.

## EXITING THE PLATFORM

Once you are at the desired landing, the lift will stop and you may release the brakes on your mobility device. When ready to exit, if desired, turn the key switch off and remove the keys.

If your platform has a platform gate or you come to a landing gate or door, those will be able to be opened by pushing outward.

### CAUTION

Check to make sure the platform is level with the landing. If not, please contact a dealer for assistance.

*NOTE: If your platform has an automatic folding ramp, it will automatically deploy only at the lower landing.*

Once you have exited the platform, ensure the gate or door has closed all the way. Call/Send controls will not work unless doors are closed.

### RECOMMENDATIONS

#### CAUTION

Platform lifts should not be used for evacuation during emergencies.

Do not use the lift alone if you are not sure that you can maintain pressure on the control buttons for the duration of travel.

If using the lift alone, it is best practice to have a cell phone with you in case of a malfunction that prevents the platform movement.

If the lift malfunctions while occupied:

- Occupant should follow the directions in the platform cab and never try to evacuate the elevator on their own.
- Contact dealer and/or 911 (dealer's phone number is written on the label next to the cab controls).
- Push in the Red Emergency Stop button on the cab control.

Once help arrives, they should follow the Emergency Lowering Procedure to evacuate the occupant.

### EMERGENCY LOWERING PROCEDURE

#### WARNING

Never exit an elevated platform unless it is fully parked at a landing. Do not attempt to manually lower the device while in the platform.

In the event that the lift becomes disabled with passengers on the platform that is not at a landing, it may be necessary/desirable to manually lower them prior to a technician arriving.

In that case, a manual lowering mechanism is located beneath the top cap of the lift. A person other than the lift passenger(s) will be required to make their way to the top of the tower to perform this procedure.

1. Use disconnect to remove all power from lift.
2. Loosen seven (7) screws around the perimeter of the top cap with a Phillips head screwdriver.
3. Flip the brake release switch up to make lowering easier.
4. Remove the two wingnuts holding down the manual lowering tool. *See Figure 3-4.*

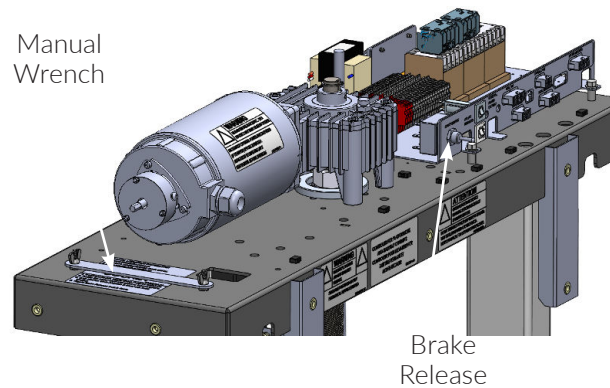

Figure 3-4

5. The wrench fits over the 1/4" hex shaft at the end of the drive motor. It is designed to be rotated by hand — clockwise, which will turn the screw and lower the platform. *See Figure 3-5.*

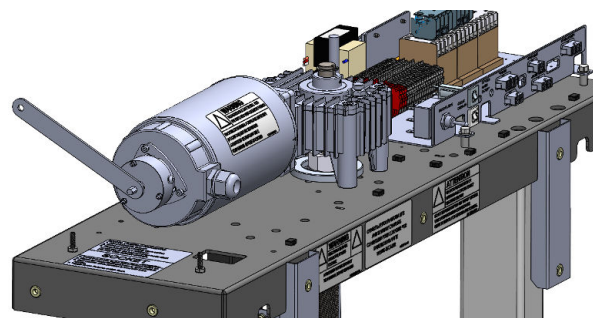

Figure 3-5

6. If you have a  $\frac{3}{8}$ " drive ratchet or a cordless drill with a  $\frac{3}{8}$ " socket adapter bit and a  $\frac{1}{4}$ " socket or  $\frac{1}{4}$ " hex bit extension (*not included*), power the drill in the forward direction - rotating clockwise to lower the platform.

**NOTICE**

*Do not drive it with an impact or hammer drill.*

*NOTE: The drive motor is equipped with a low holding force brake to prevent the platform from drifting with heavy loads. Lowering the platform with this brake on will require a bit of strength, typically the equivalent of being able to lift 20 lb with one arm.*

7. Rotate the motor shaft clockwise to lower the platform.

*NOTE: Do not attempt to raise the platform. The required torque to do so is substantially higher.*

8. Stop rotation when the platform is level with the lower landing.
9. Return the Brake Release switch to the down position to re-engage the brake.
10. If the platform gate doesn't open, use the interlock key to open the gate from the outside.



**WARNING**

**Wait for a Harmar dealer to service and inspect the lift prior to using it again.**

## SECTION 4

# CARE

To maximize longevity and appearance of your lift, Harmar recommends the following procedures:

- Keep the VPL platform free of debris. Sweeping to clear these areas regularly to prevent debris accumulation is required. Wiping with a damp cloth should be enough for additional surface cleaning. If needed, a soft brush with mild soap and water can be used on the platform and guard ramp surfaces
- You may choose to clean your VPL with soap and water. Turn off VPL and disconnect all power before cleaning. Be sure to rinse all soap from VPL and let the VPL dry before using.
- Keep door hinge hardware lubricated. Once a year use lubricant on the hinges.
- On an outdoor VPL, if the lift will not be used for long periods of time, covering the platform with a tarp and disabling the power is recommended.
- Fully disconnect the lift from all power if not using for 2 months or more. Please consult your dealer for proper disconnect procedures.
- Yearly wax (car wax) is an excellent means to protect an outdoor VPL from weather.

## SECTION 5 **MAINTENANCE & INSPECTION**

Annual inspections are required to help prevent unsafe conditions and operation.

### **RESIDENTIAL APPLICATIONS OWNER / MAINTENANCE PERSONAL**

#### **BEFORE USE**

Do not use lift until these conditions are rectified.

- All doors and gates are locked and secure.
- Ensure there is no standing water around the unit.
- Make sure the AC connections are in good condition and that there are no cracks or gaps in conduit.
- Make sure there are no obstructions intruding in the path of the lift.
  - People, tree branches, loose items, etc.
- Check that there is no loose hardware or emerging cracks/deformations in the platform and tower. Make sure that there are no unusual noise or vibrations that develop.

#### **PERIODICALLY**

- Check and ensure that the safety pan under the platform moves freely up and down and is not damaged. This is the built-in safety device designed to detect obstructions under the platform and stop platform downward motion. If there is an easy-to-remove obstruction, please remove it. If for any reason the safety pan does not move as intended, please contact your dealer.
- Check and ensure that all labels are intact and legible. If any safety or warning labels need to be replaced, please contact your dealer.
- Make sure you have a copy of the Owner's Manual. A digital copy of the Owner's Manual is available at [harmar.com](http://harmar.com).

- Check your key locks and emergency stop button for functionality. Ensure user understands overrides and understands how to manually open the gate in the event of an emergency.
- Check for any rust that may be developing. Rust is expected in outdoor applications (especially in coastal areas), but with proactive maintenance or quick repair, this can be minimized.

#### **IMPORTANT**

Understanding State/Local Inspection Requirements and Timing - Always Required.

### **MAINTENANCE SCHEDULE RECOMMENDED EVERY 6-MONTHS**

#### **NOTICE**

*We recommend this be performed by a qualified service technician.*

- Check for motor gearbox leaks
- Check wear pads for gaps
- Lubricate ACME screw with Nook PAG-1 ACME Screw Grease. Check all structural connections/hardware
- Inspect the safety brake
- Ensure the electrical disconnect works as intended
- Check all interlocks and obstruction sensors

**MAINTENANCE**

---

**MAINTENANCE/SERVICE RECORD**

Safety standard ASME A18.1-2020 requires that a log is kept of all service and maintenance performed on this lift in residential applications. This includes a record of all accidents and operational checks. Refer to “Install and Service Manual” for operational check list. To ensure optimal performance it is recommended that this log is kept for residential applications as well.

Date	Time	Type of Service (check all that apply)				Notes, Nature of Service/Accident, Parts Replaced, Warranty	Technician
		Check	Repair	Maint.	Accident		

**MAINTENANCE**

Date	Time	Type of Service (check all that apply)				Notes, Nature of Service/Accident, Parts Replaced, Warranty	Technician
		Check	Repair	Maint.	Accident		



# WARRANTY



## SECTION 7

# 2-YEAR LIMITED WARRANTY

### PRODUCTS COVERED: 400-X SERIES MODELS

Your lift came with a separate warranty page on page 17. You must return that page within ten (10) days of installation to register your lift. This warranty policy page must remain in your Owner’s Manual for your records. Do not tear out this page.

Dealer/Installer Name: \_\_\_\_\_

Address: \_\_\_\_\_  
\_\_\_\_\_

Phone: \_\_\_\_\_

E-Mail: \_\_\_\_\_

If you need service or warranty work, your dealer will require the information below to receive factory information or order parts for your VPL.

Date Purchased: \_\_\_\_\_

Serial # of the Lift: \_\_\_\_\_

**THIS EXPRESS WARRANTY IS IN LIEU OF ALL OTHER WARRANTIES OR CONDITIONS, INCLUDING ALL IMPLIED WARRANTIES OR MERCHANTABILITY OR FITNESS FOR A PARTICULAR PURPOSE, AND THERE ARE NO WARRANTIES THAT EXTEND BEYOND THE DESCRIPTION OF THE LIMITED WARRANTY DESCRIBED HEREIN. THIS WARRANTY GIVES YOU SPECIFIC LEGAL RIGHTS AND YOU MAY ALSO HAVE OTHER LEGAL RIGHTS WHICH VARY FROM STATE TO STATE.**

Harmar Mobility warrants, to the original purchaser of a Highlander 400-X Vertical Platform Lift (VPL), that the device has been manufactured by Harmar to be free of defects in material, mechanical and electrical component (parts), excluding labor costs, and paint, for a period of two (2) years from date of installation, provided that the products have been installed, maintained and operated properly. Paint adhesion and deep rust is limited to one (1) year. Outdoor installation within one (1) mile of coastline expressly excludes rust after 90-days. Cosmetic rust is excluded after 90-days in all applications.

This warranty does not cover maintenance or adjustments. Harmar will not be charged for labor, consequential damage, or repair expenses. Harmar will not, under any circumstances, be liable for the loss of the use of its products or loss of time. This warranty becomes null and void if the product has been lost, damaged by accident, over-stressed, misused and/or neglected, or if the product has been modified in any way. Defective parts must be returned, prepaid, to the address provided by Harmar, for inspection prior to credit, repair, or replacement, at Harmar’s option. Harmar’s sole obligation and the exclusive remedy under this warranty is limited to such credit, repair, or replacement.





**PLEASE FILL OUT ALL FIELDS AND RETURN WITHIN TEN (10) DAYS OF PRODUCT INSTALLATION.**

Fax completed form to 1-866-234-5680 or mail to:  
Harmar, ATTN Warranty Department, 1500 Independence Blvd., Suite 220, Sarasota Florida 34234.

### PRODUCT INFORMATION

Model: \_\_\_\_\_  
Serial Number: \_\_\_\_\_  
Purchase Date: \_\_\_\_\_  
Installation Date: \_\_\_\_\_

### PURCHASER INFORMATION

Name: \_\_\_\_\_  
Address: \_\_\_\_\_  
\_\_\_\_\_  
Phone: \_\_\_\_\_  
Email: \_\_\_\_\_

### INSTALLER INFORMATION

Company Name: \_\_\_\_\_  
Contact Name: \_\_\_\_\_  
Address: \_\_\_\_\_  
\_\_\_\_\_  
Phone: \_\_\_\_\_  
Fax: \_\_\_\_\_  
Email: \_\_\_\_\_

### ADDITIONAL INFORMATION

**How did you hear about Harmar?**

- Harmar Dealer
- Internet
- Magazine  
Which: \_\_\_\_\_
- Friend or Acquaintance
- Saw Harmar product somewhere
- Other: \_\_\_\_\_

### APPLICATION INFORMATION

- Scooter     Power Wheelchair
- Wheelchair

Year: \_\_\_\_\_  
Manufacturer: \_\_\_\_\_  
Model: \_\_\_\_\_

**Do you have Internet access:**     Yes     No

**I purchased my Harmar lift because of:**

- Style/Appearance
- Harmar Representative
- Previous Experience
- Ease of Use
- Recommendation
- Price/Value



**Page Intentionally Left Blank**



1500 Independence Blvd. Suite 220  
Sarasota, FL 34234  
800-833-0478  
[www.harmon.com](http://www.harmon.com)